



RINSING



NEW



FILLING



SEAMING



CAN **BLOCK 6/6/1-LE**

*Fully automatic electronic canning machine
Rinsing, isobaric filling and seaming
Beer, Cider, Soft Drinks, Wine, etc.*

Sturdy, Compact, Electronic, Reliable

***Output:
up to 1.500 cans hour***

FRAMAX

CAN BLOCK 6/6/1-LE

Fully automatic electronic canning machine. Rinsing, isobaric Beer, Cider, Soft Drinks, Wine, etc.

The CANBLOCK is a fully automatic electronic canning machine including a 6 position rinser, 6 valve electro-pneumatic counterpressure filler and a single-head seamer with automatic lid dispensing system.

Each phase can be fully programmed



Details

- Sturdy frame, resistant to bending and vibrations
- Rinsing by tilting the cans 180°
- Automatic filling cycle (electro-pneumatic)
- Electronic control of the different phases, with settings adjustable from the operator's panel
- Multiple CO2 flushing system to minimize oxygen pickup
- Buffer tank included to provide constant product supply
- Easy and fast maintenance operations
- CIP predisposition
- All parts in contact with the product made in stainless steel AISI 304 or AISI 316.

Rinser



Filler



filling and seaming.

**Output:
up to 1.500 cans/hour**

SMALL CANNING



**BEER, WINE, CIDER,
SOFT DRINKS**



*Touch screen
control panel*



*Multiple recipe
Management: Each phase
can be fully programmed
by the operator to suit
the product to be filled
(Vacuum, CO2 injection,
filling, snifting).*

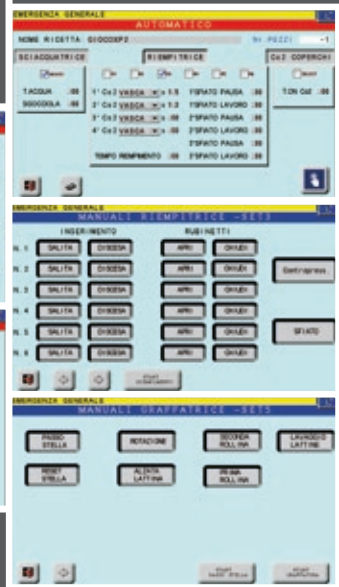

Seamer

CIP Mode

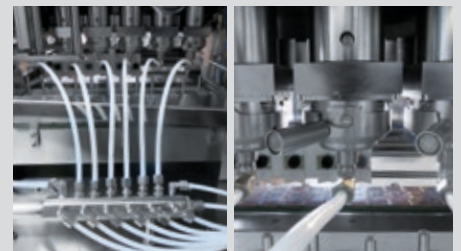
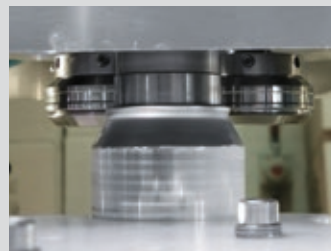

CAN BLOCK 6/6/1-LE

Sturdy, Compact, Electronic, Reliable

Technical data:

- Can Height range 115-170mm (or on request)
- Inlet product: DN 40
- Work height from floor: 1.050mm +/-50mm
- Display: colour touch screen
- Approx. overall dimensions: mm 2150*1050*2350h
- Machine manufactured according to CE safety regulations.

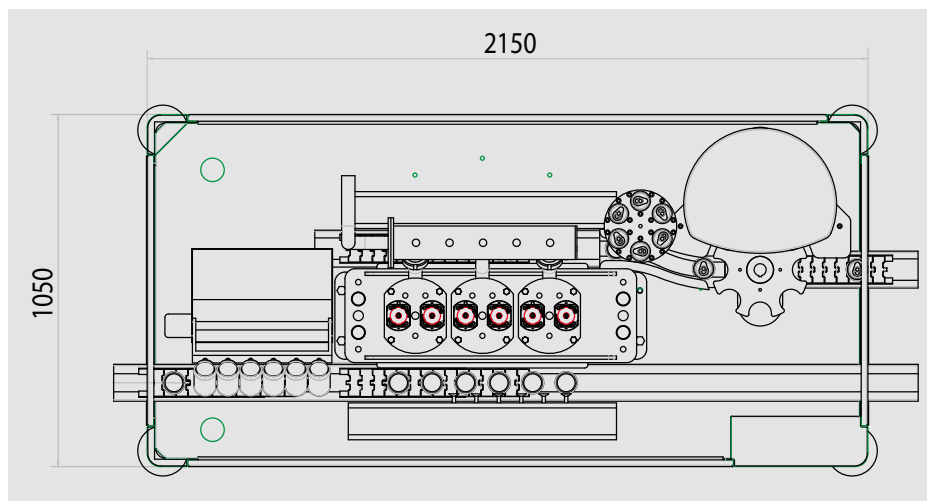

Optional:

- Labeller at inlet
- Hot foil printer for labels
- Shower at the outlet
- Collection table
- Wheels

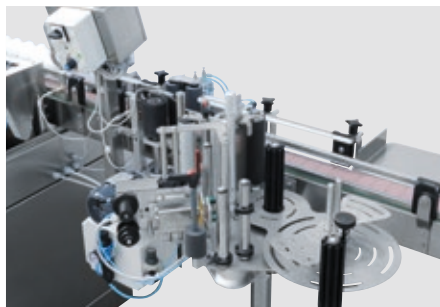

Labeller

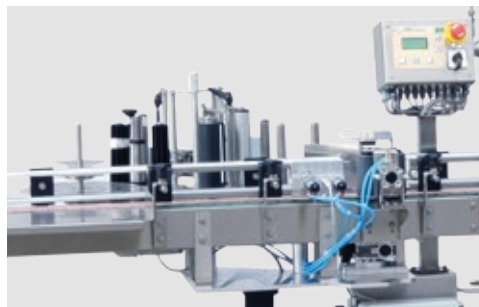

For additional information visit: www.framax.com

FRAMAX

FRAMAX srl - Via Marlianese, 31
51030 Serravalle Pistoiese (PT) Italy
Ph./Fax +39 0573 51435 - Fax +39 0573 079907
email: info@framax.com